

# UDTJ150 - Egg centrifuge

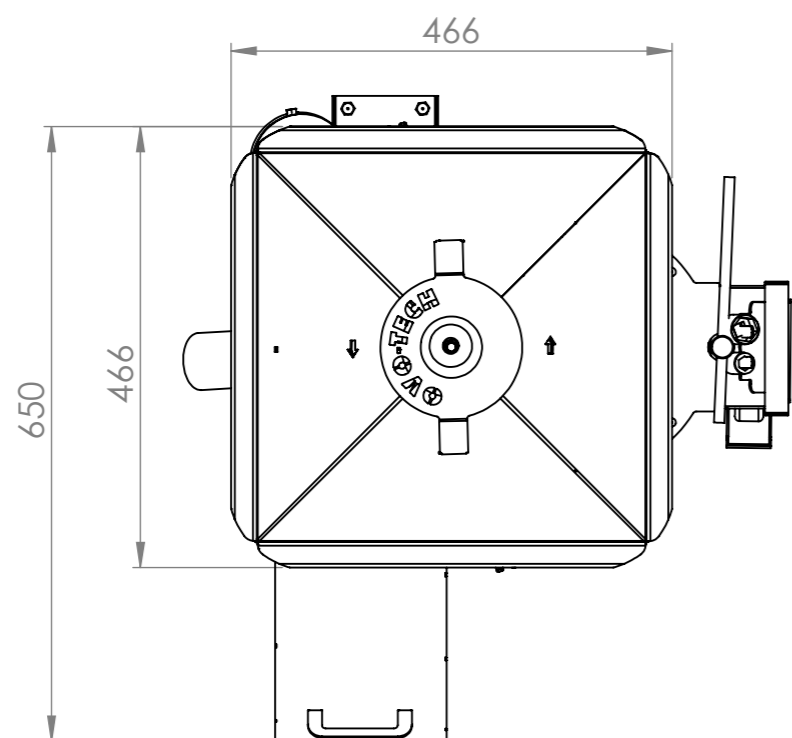
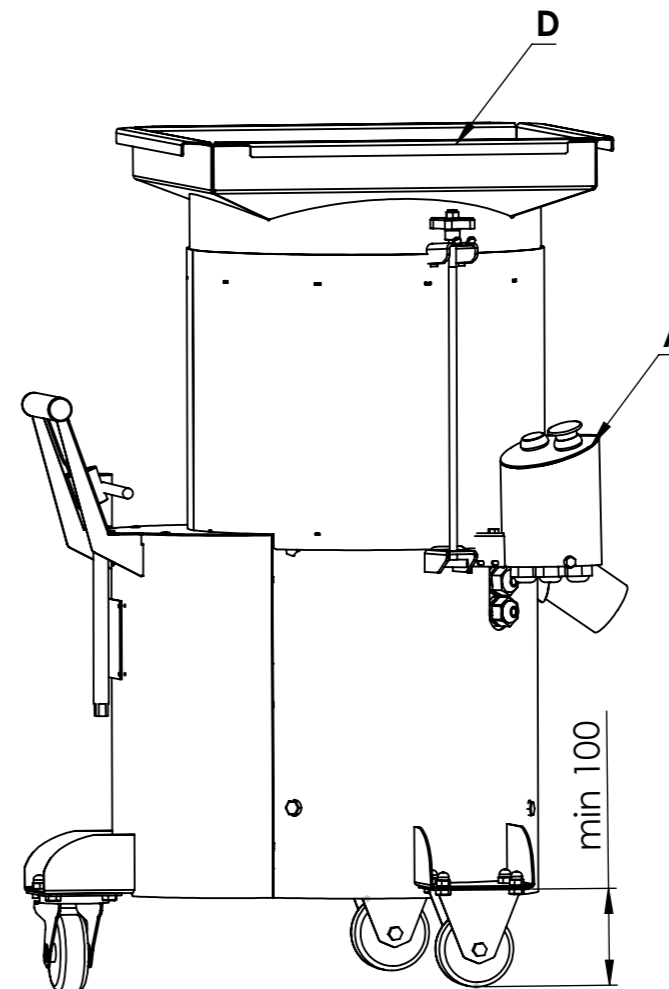
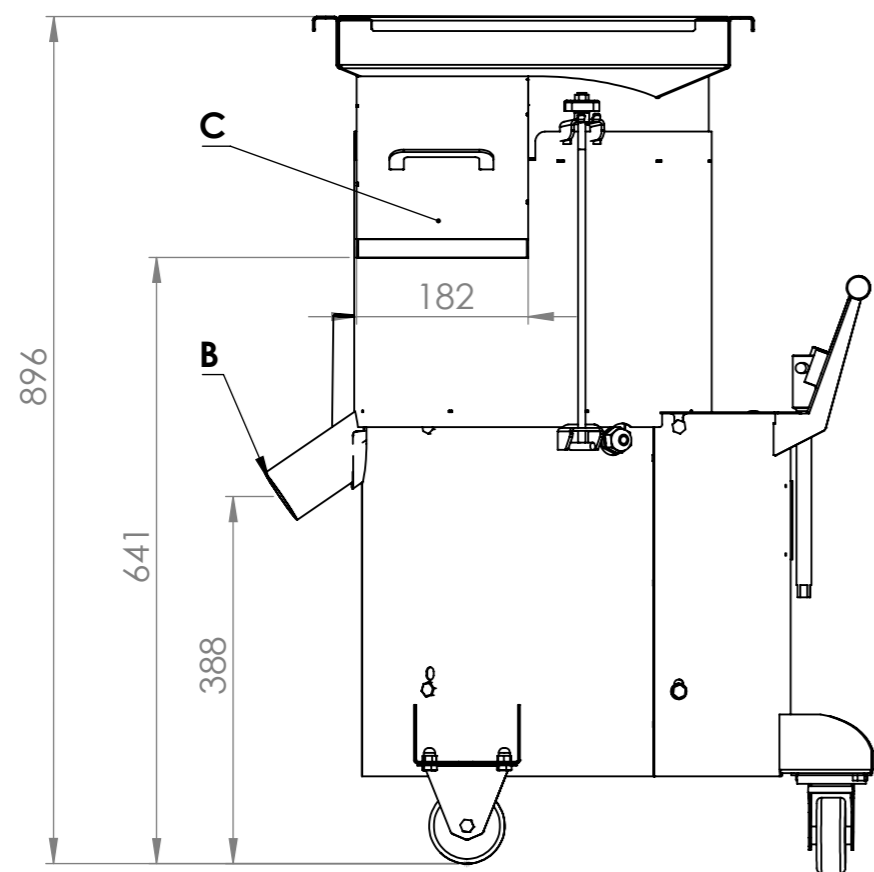

**Capacity 12000 eggs/h (max 20000 eggs/h)**

- A** - Control panel
- B** - Out liquid egg
- C** - Out of egg shell
- D** - Egg input

Total power supply 1,1kW 400V 3/N/PE 50/60 Hz  
230V 3/N/PE 50/60 Hz

Total weight: 80kg

Necessary minimum distance to walls

- to the rear side 350mm

Minimum workspace: 1000x1000

**OVO-TECH**

RESERVED AND CONFIDENTIAL  
INFORMATION INCLUDED IN THIS  
DRAWING ARE SOLELY OWNERSHIP  
Piotr Drapejkowski.  
ANY REPRODUCTIONS OF PARTS OR  
WHOLE WITHOUT WRITTEN CONDITION  
Piotr Drapejkowski are  
PROHIBITED.

**UDTJ150 - Egg centrifuge**